

B747-8F Unit Load Devices

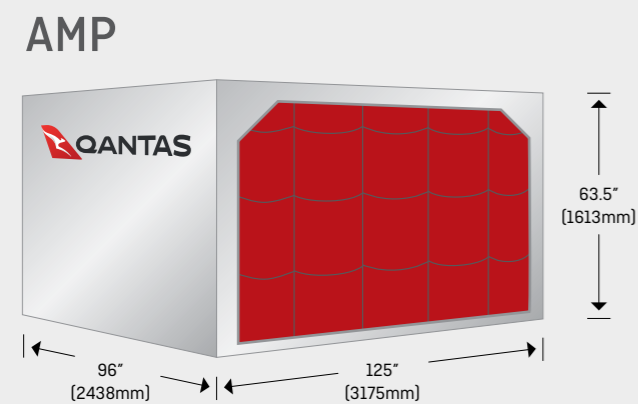
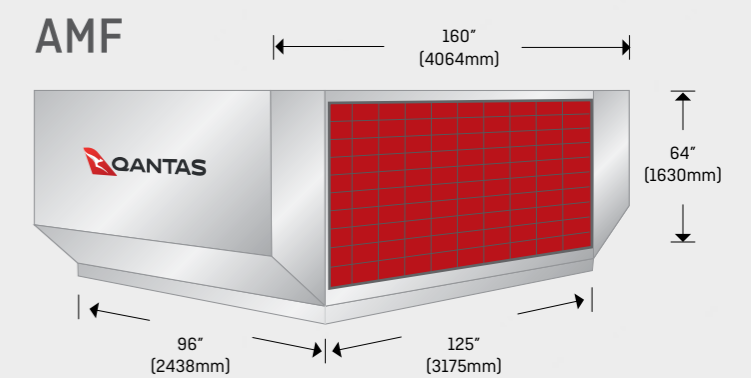
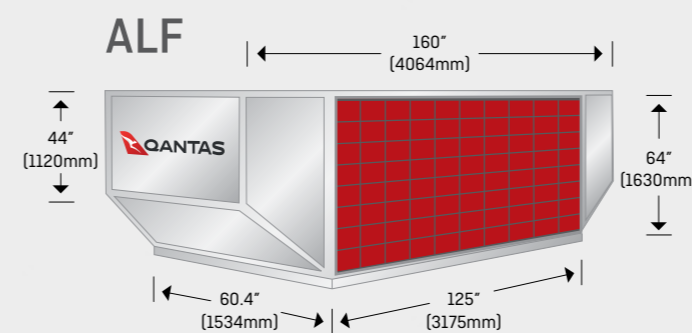
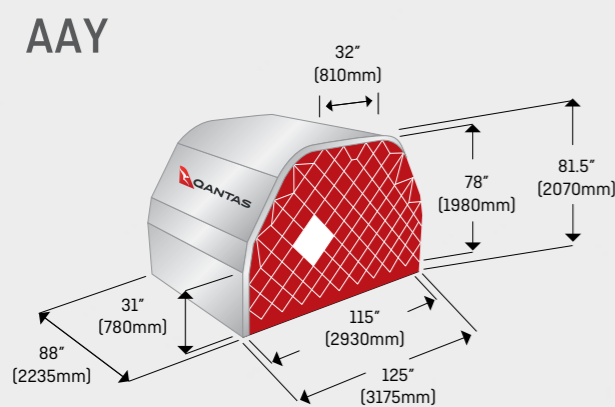
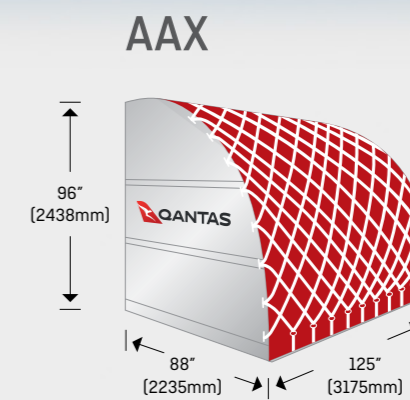
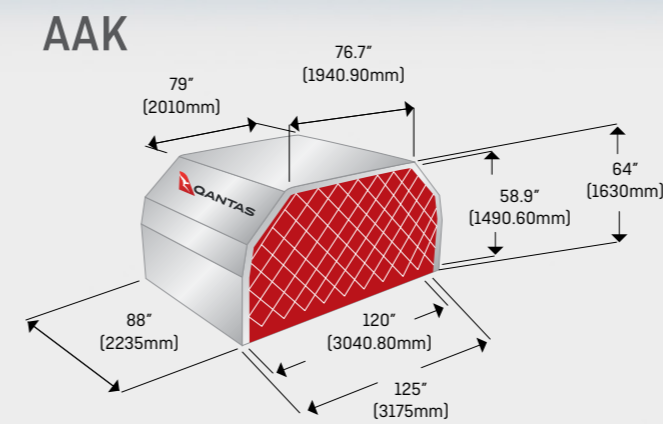
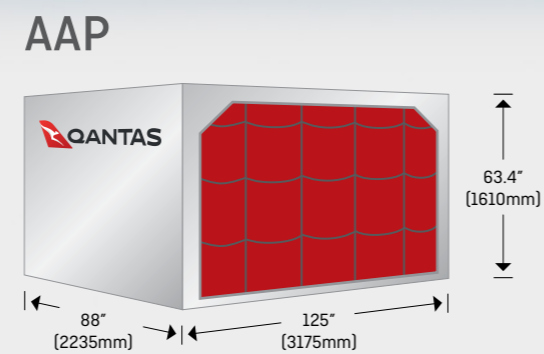
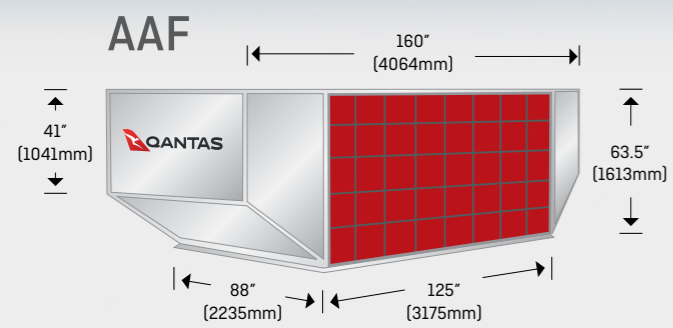

B747-8F

Unit Load Devices

Continued

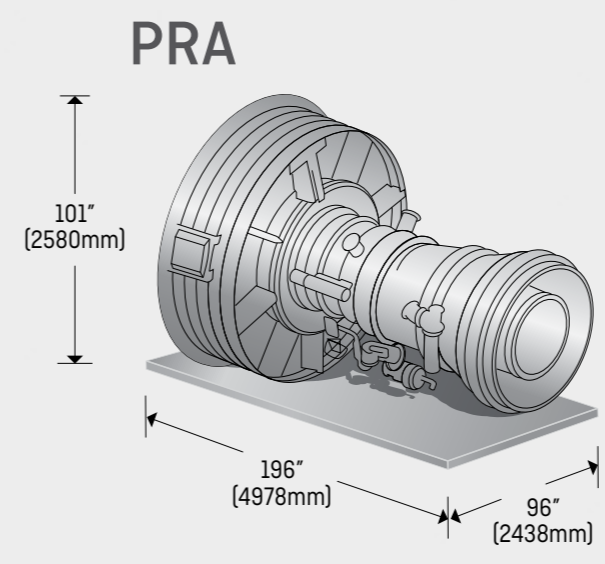
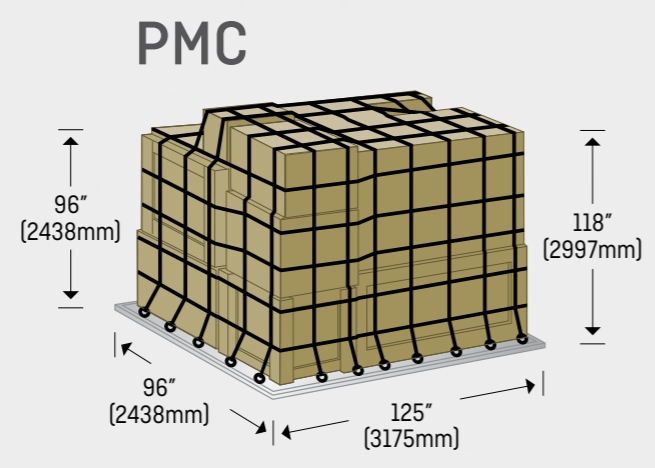
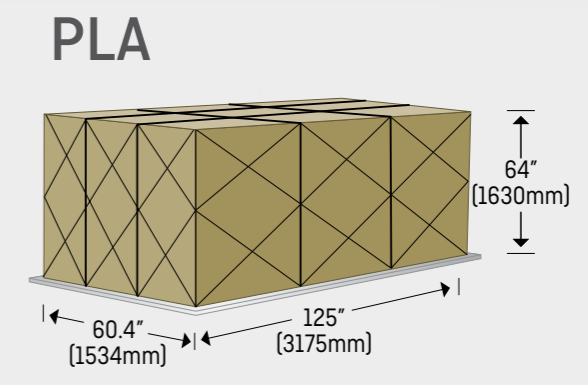
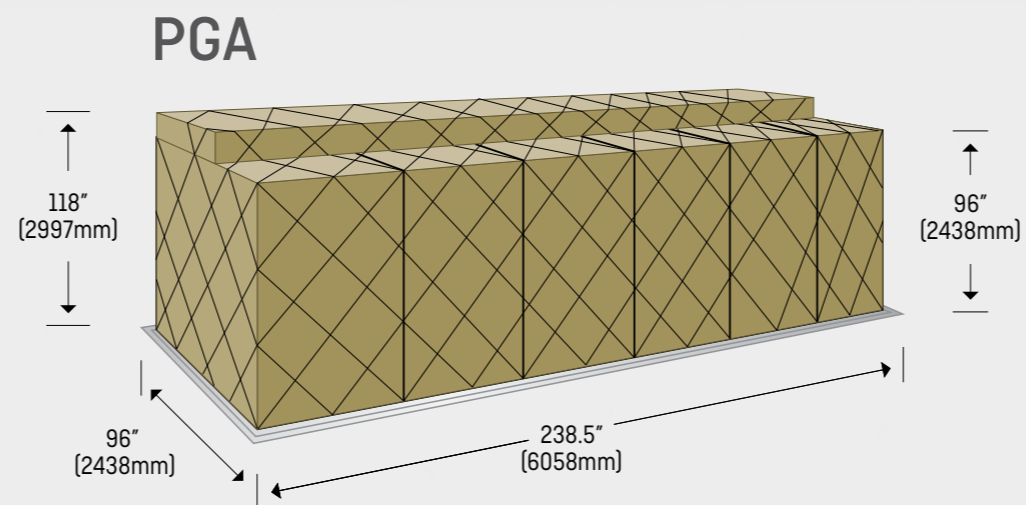
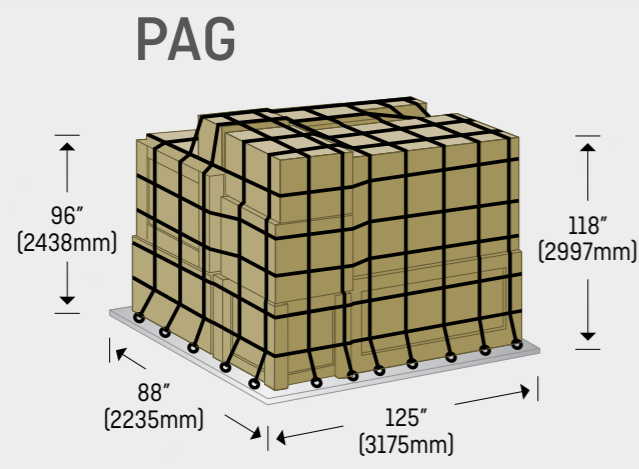

B787-9 Unit Load Devices

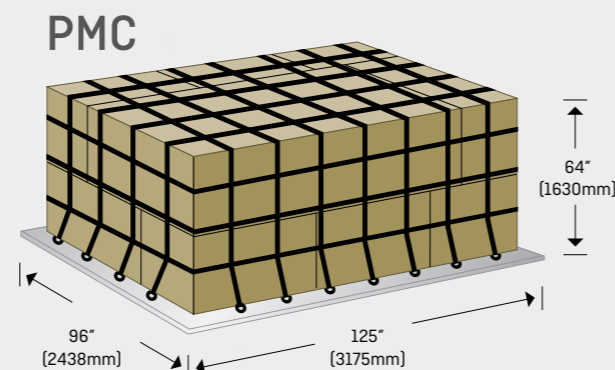
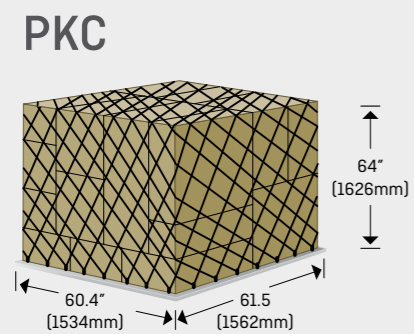
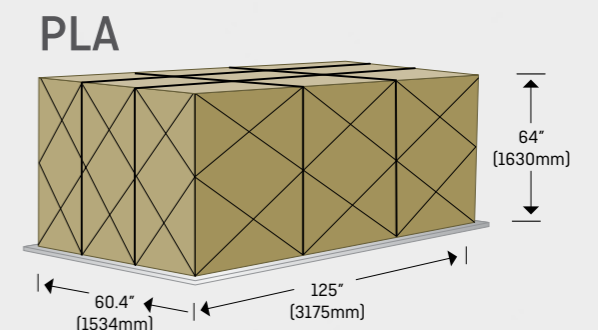
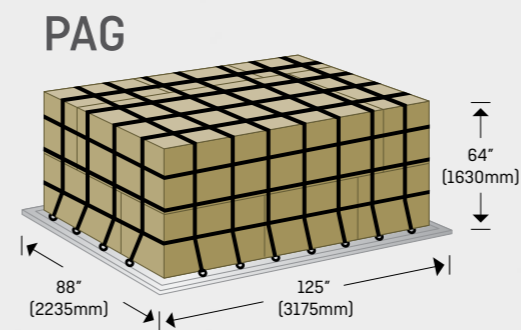
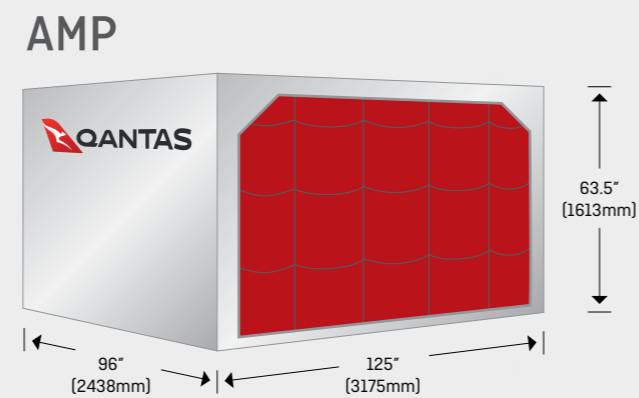
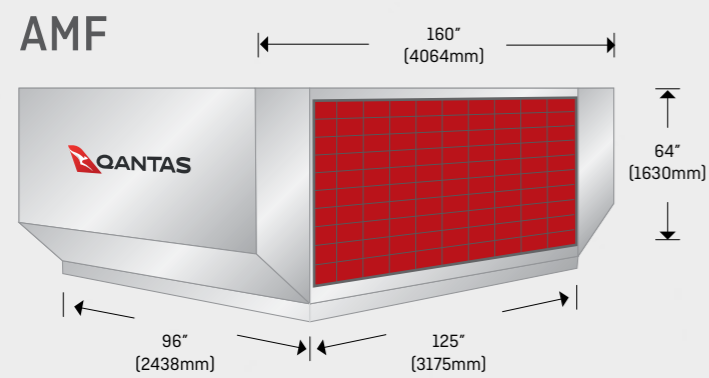
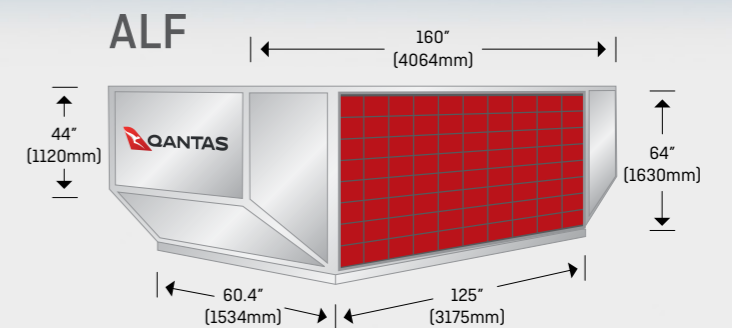
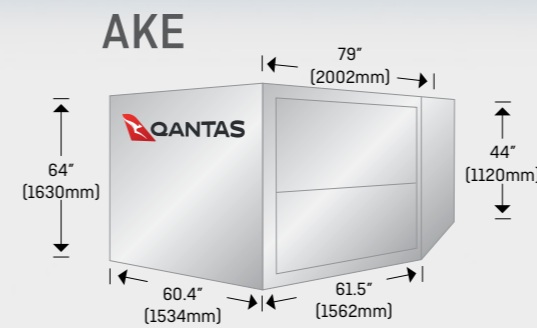
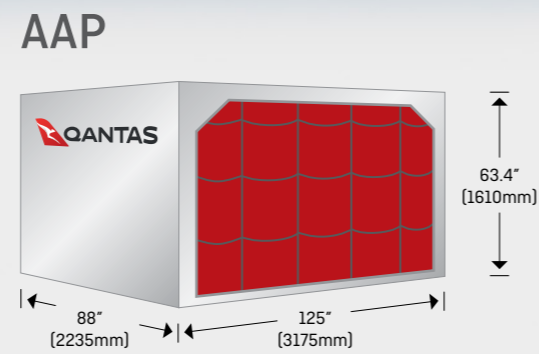
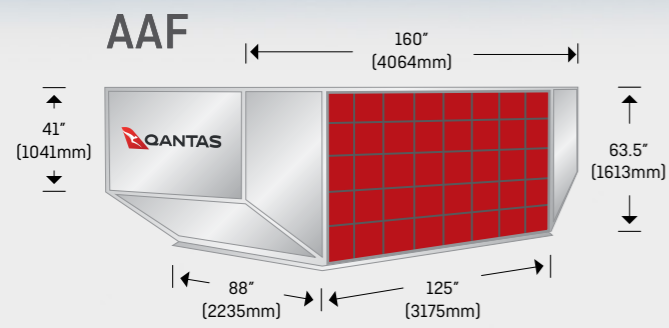

B767-300F Unit Load Devices



AAK

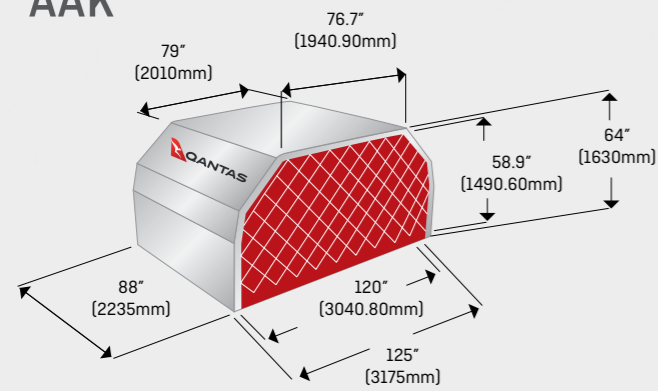

AAX

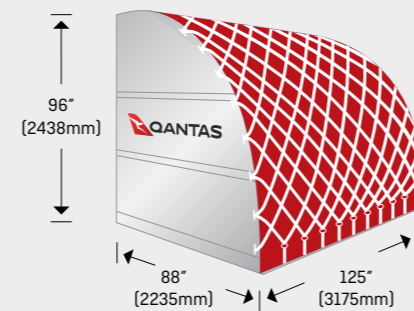

AAY

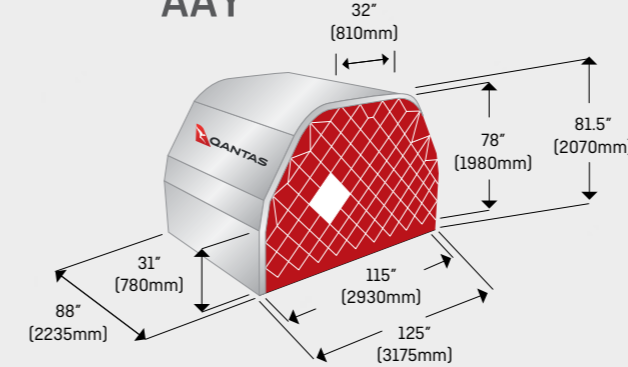

AKE

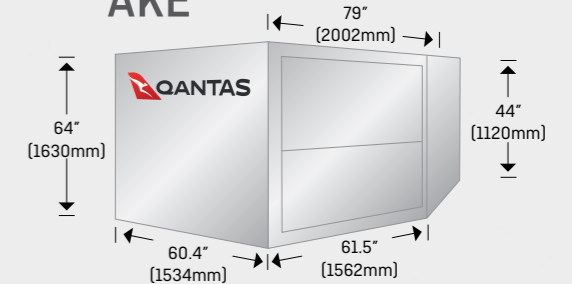

DQF

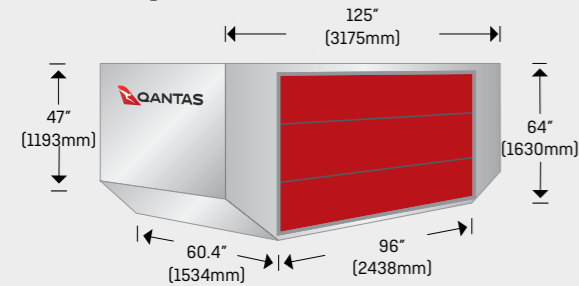

PMC

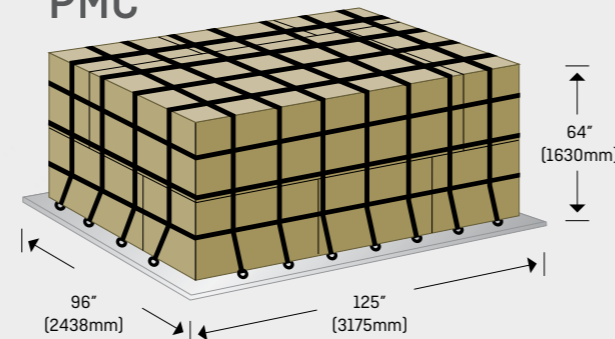

PAG

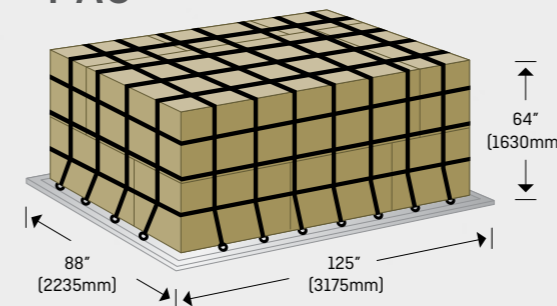

PRA

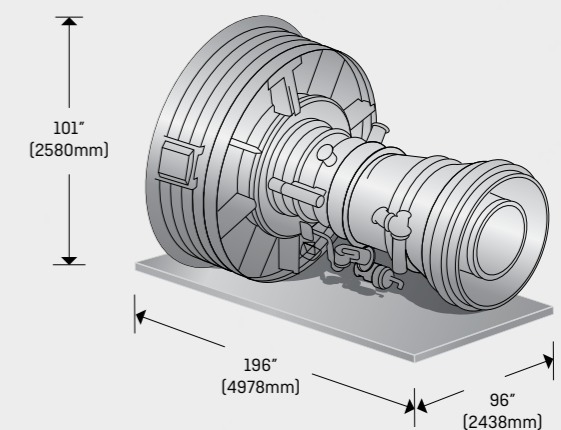

B737-400F Unit Load Devices



AAY

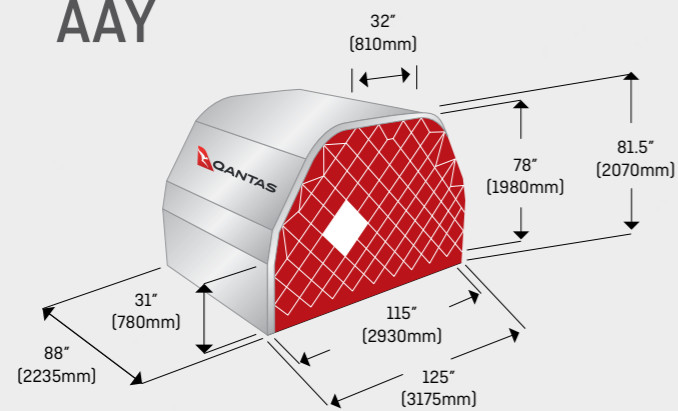

ABB

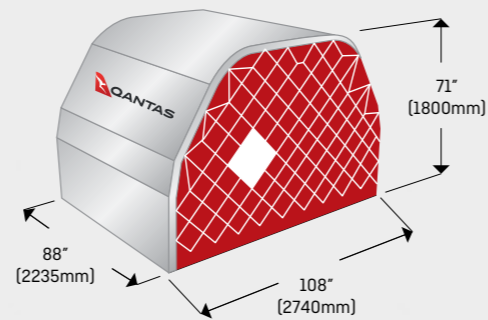

AEP

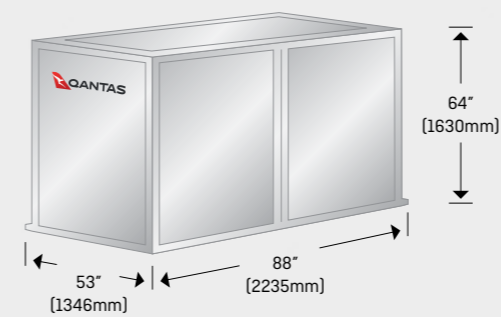

AKE

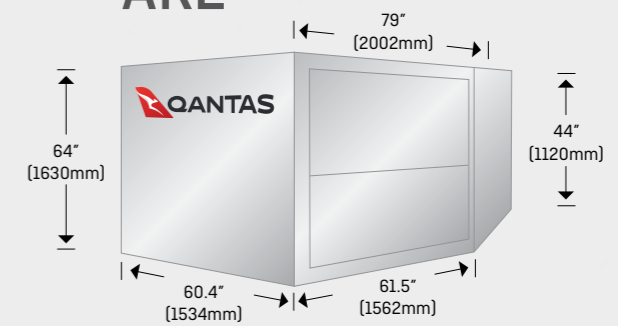

PEB

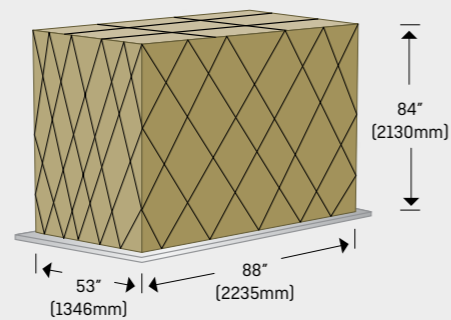

PAG

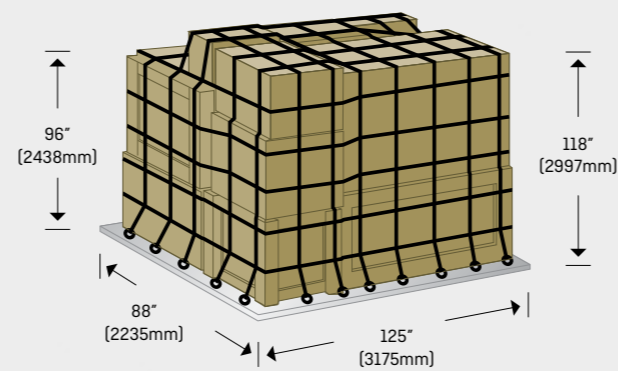

PMC

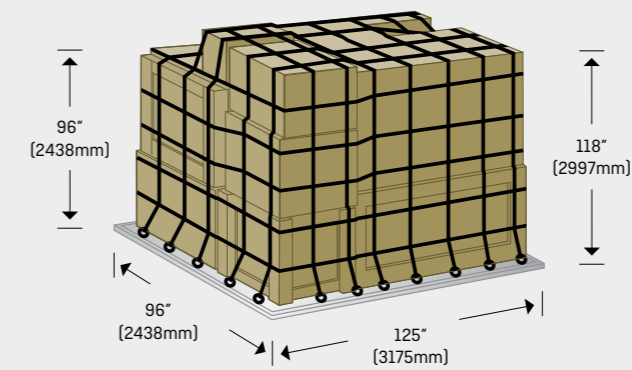

B737-300F Unit Load Devices

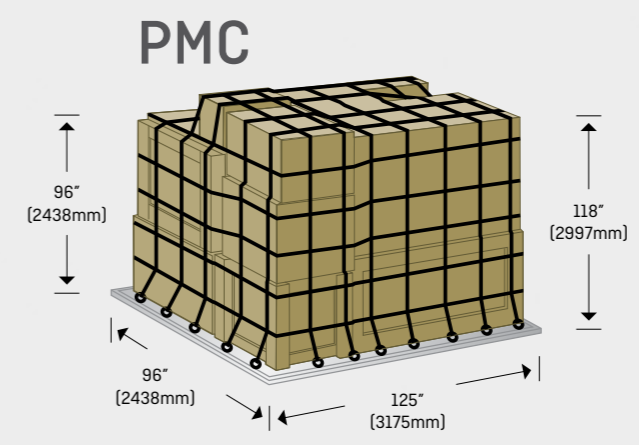
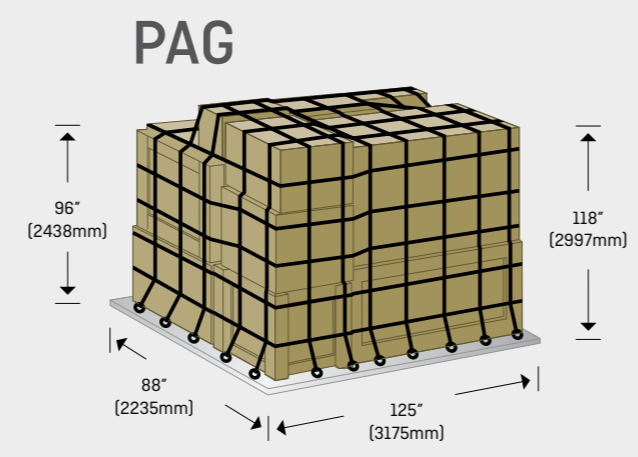
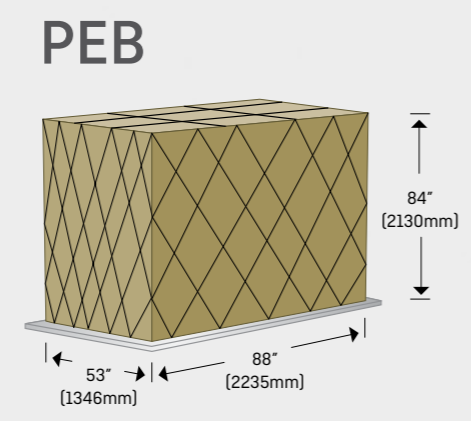
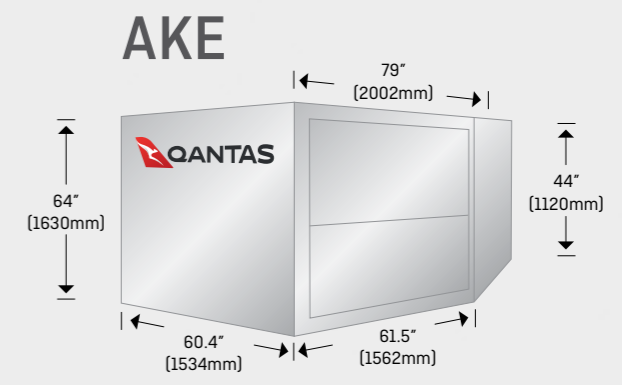
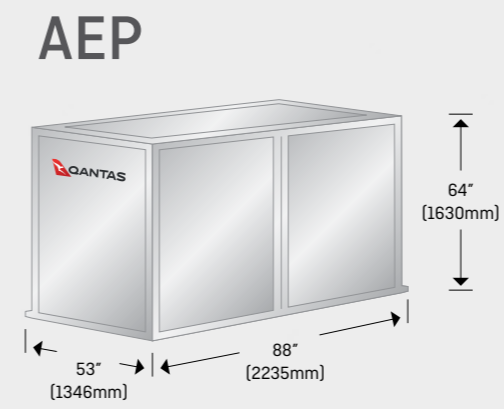
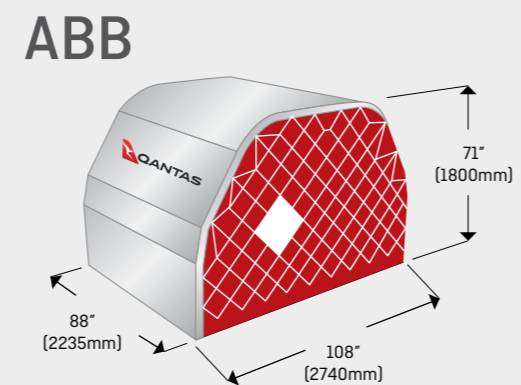
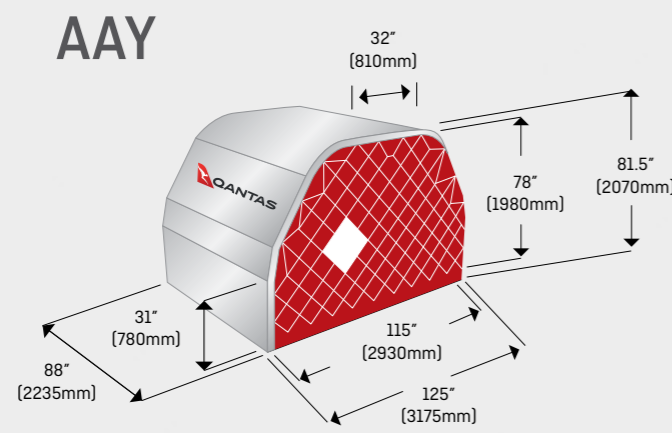

A380-800 Unit Load Devices

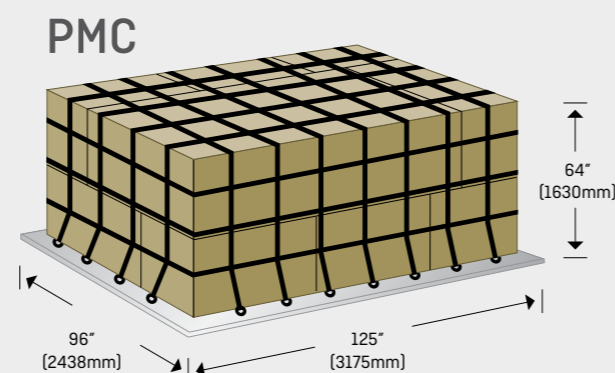
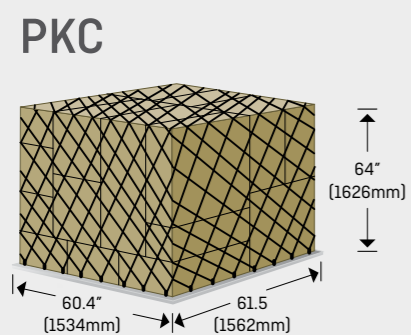
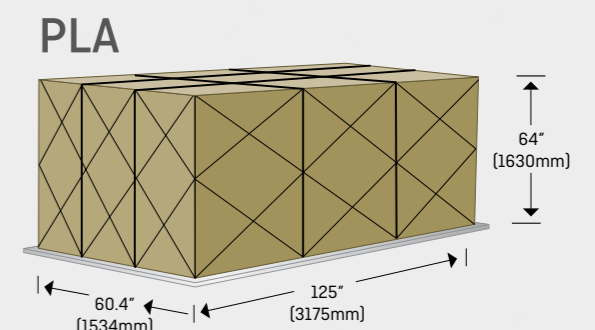
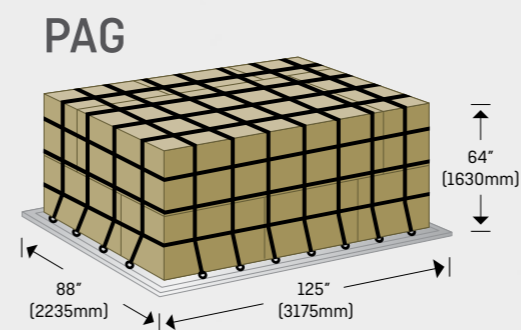
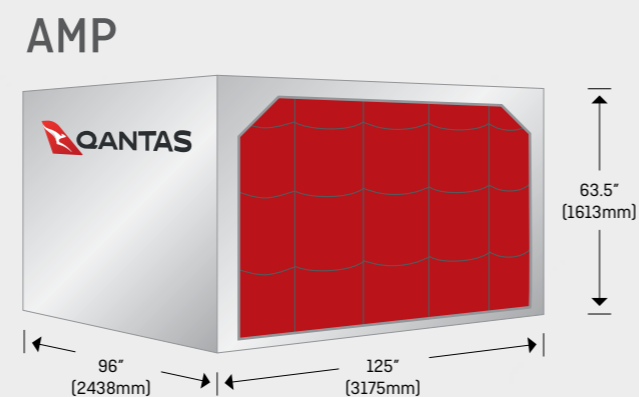
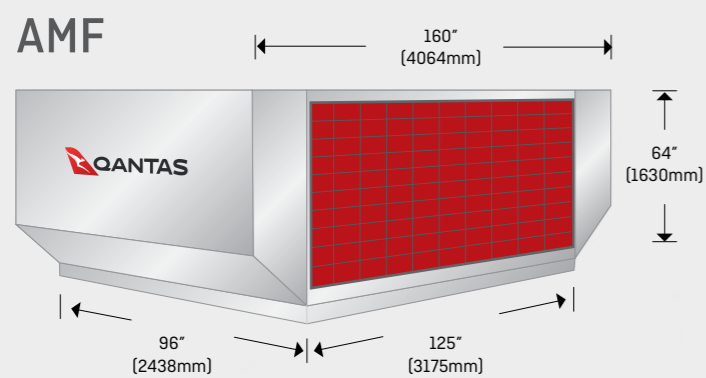
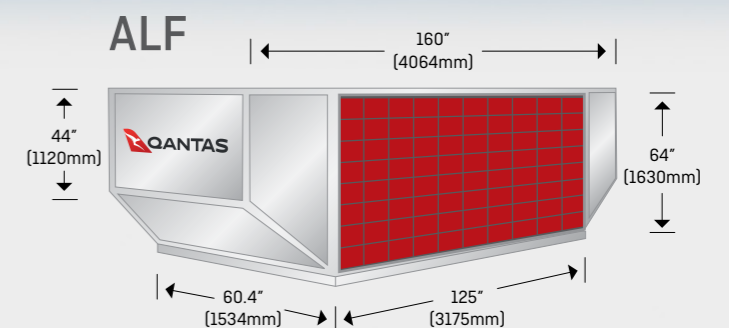
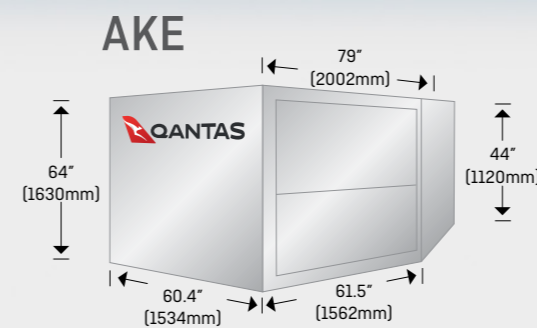
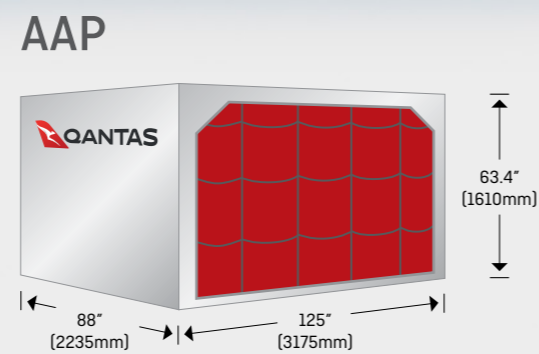
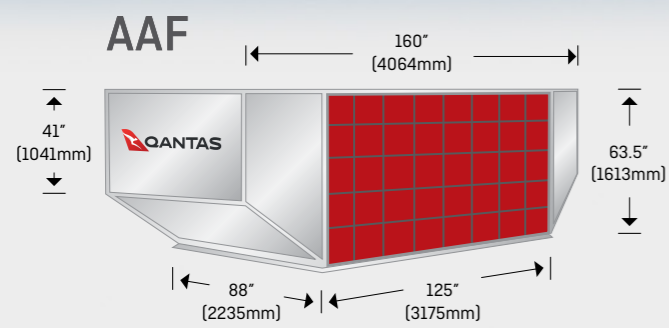

A330-300 Unit Load Devices

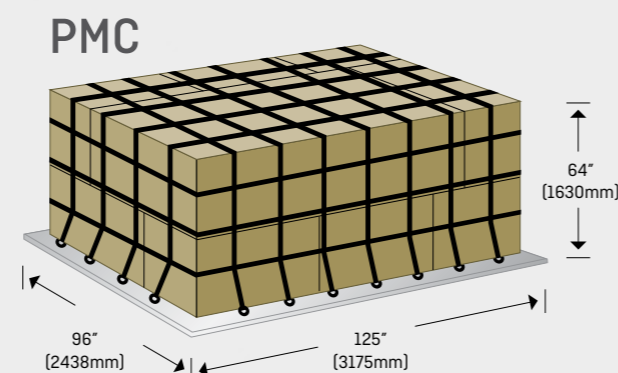
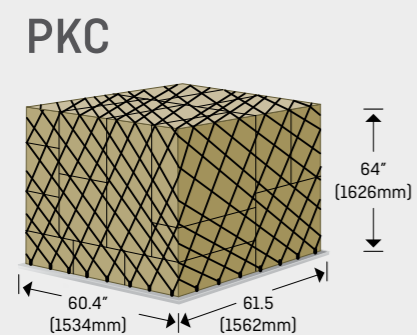
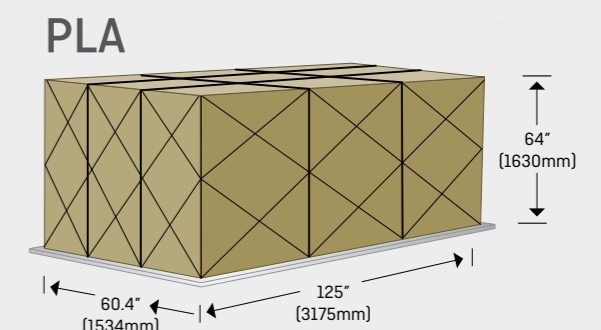
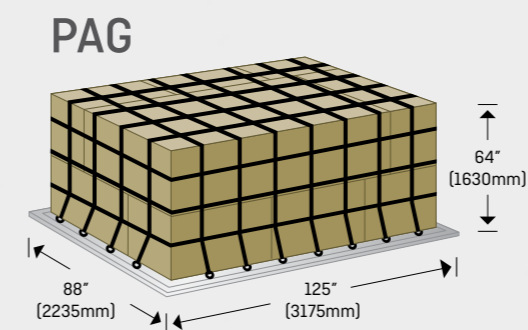
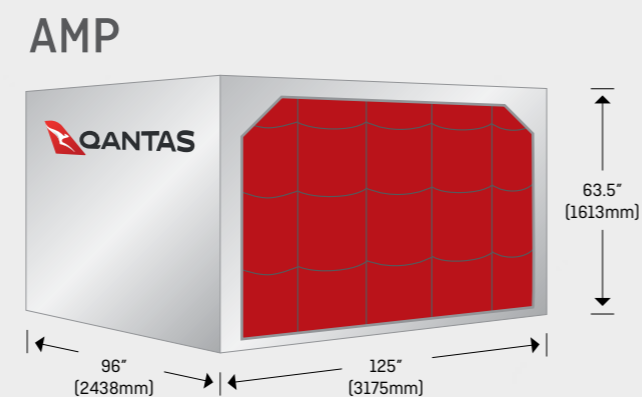
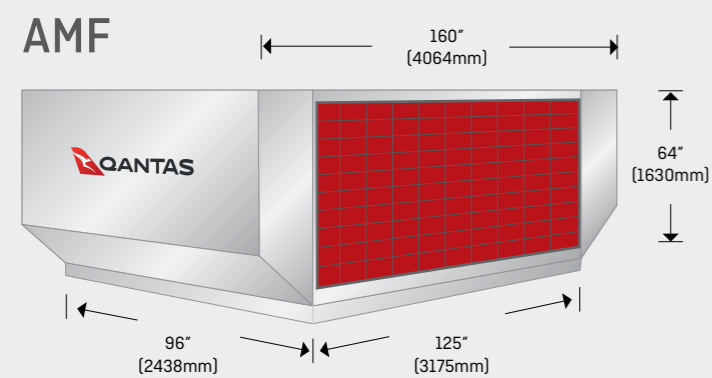
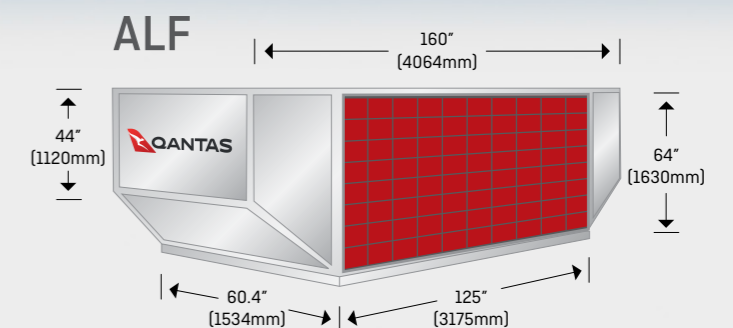
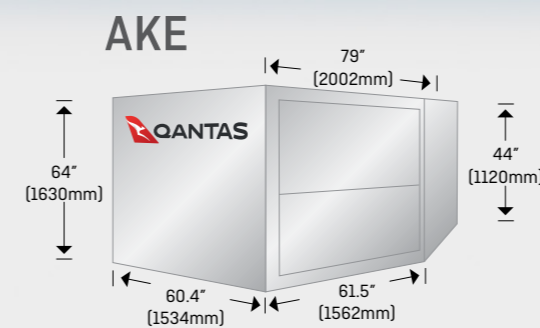
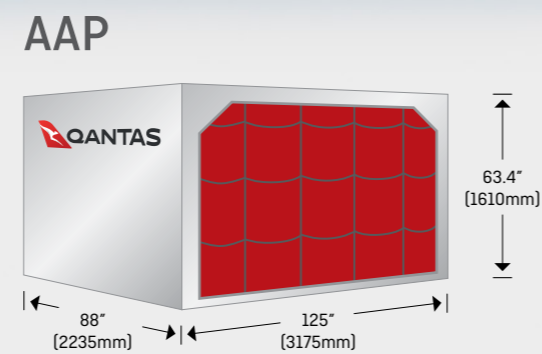
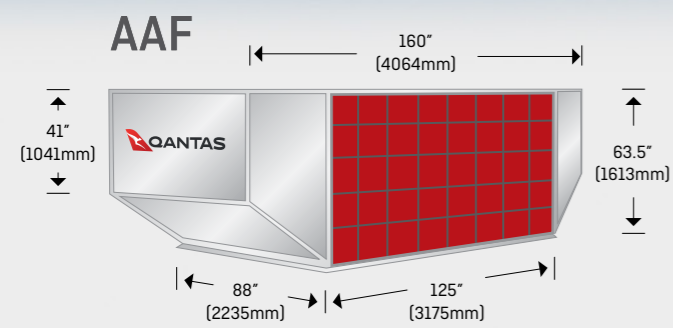

A330-200 Unit Load Devices

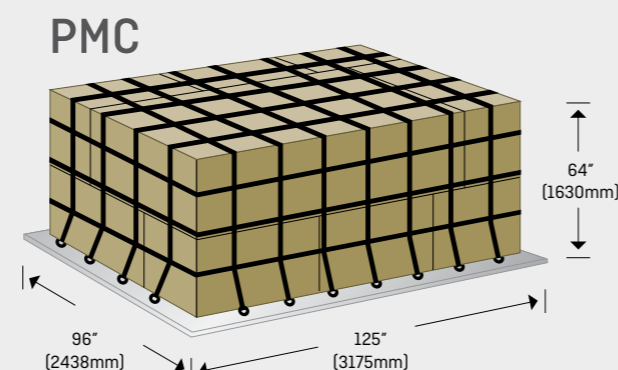
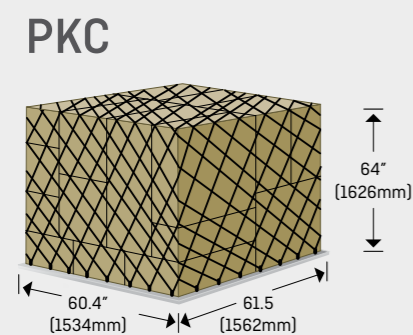
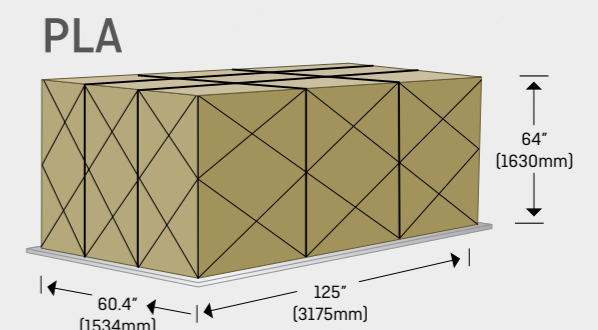
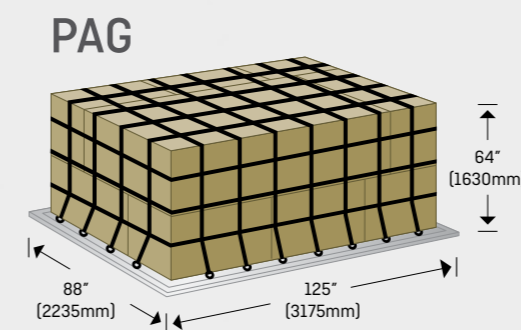
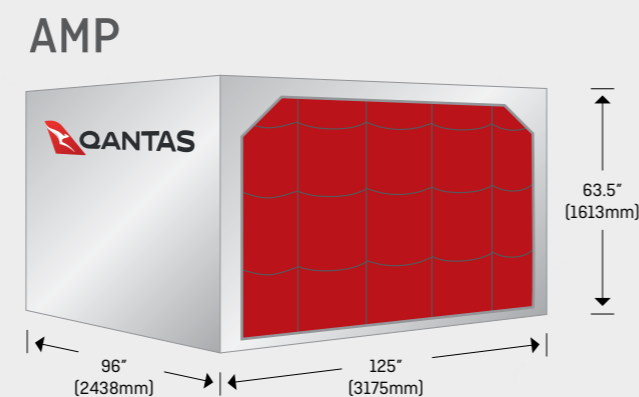
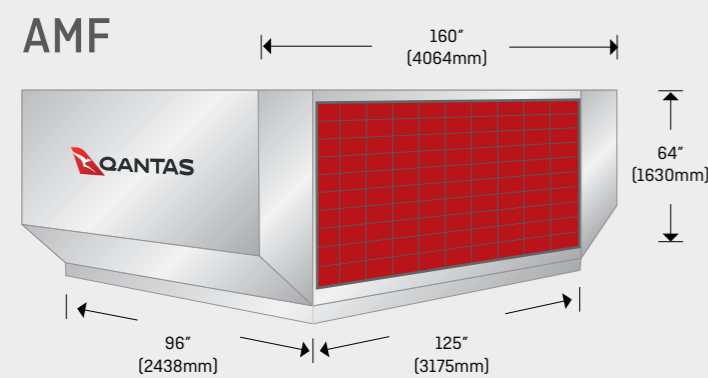
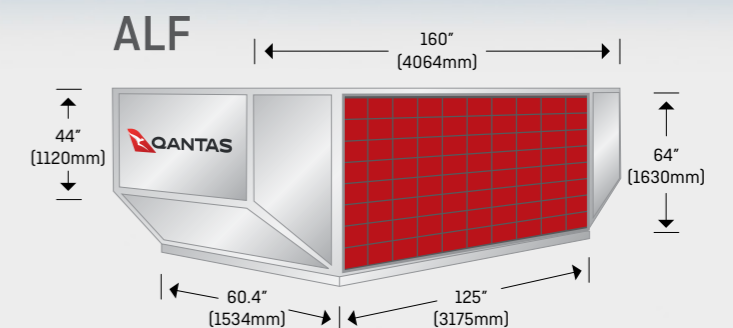
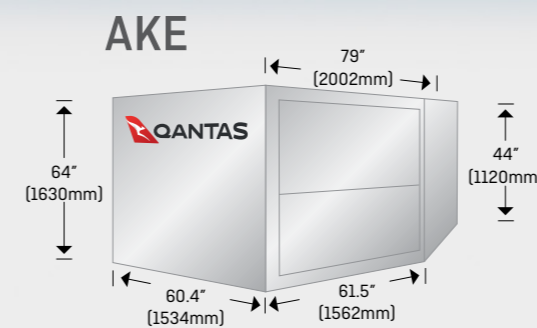
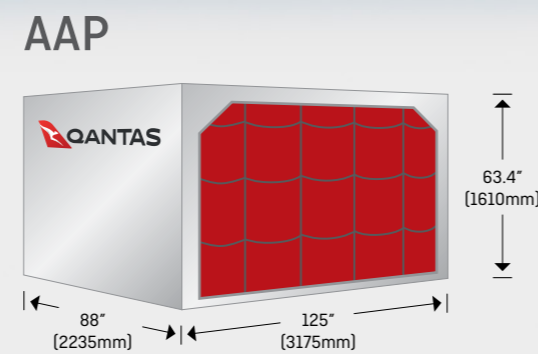
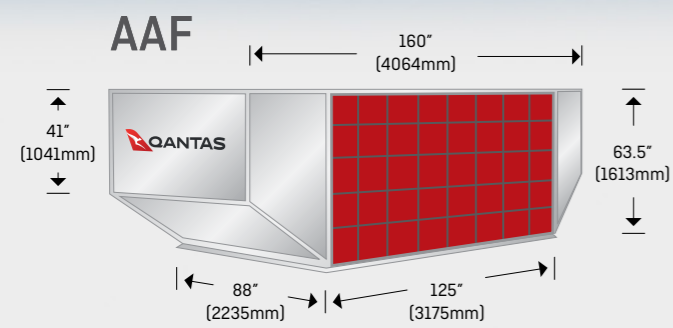

BaE 146-300QT

Unit Load Devices



ABB

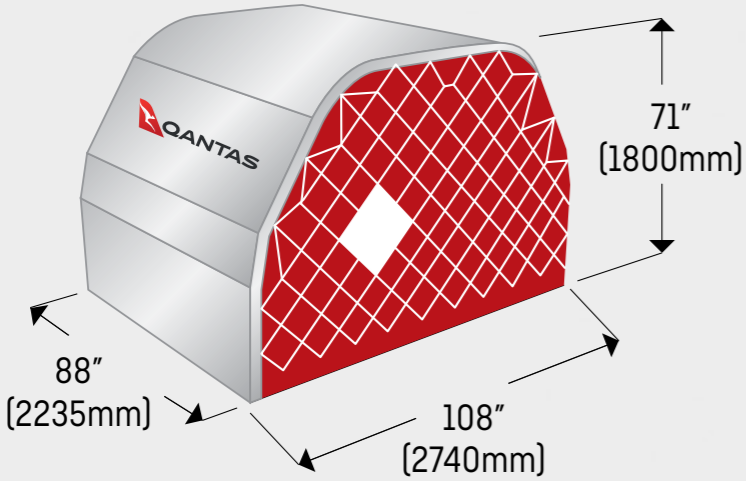

AEP

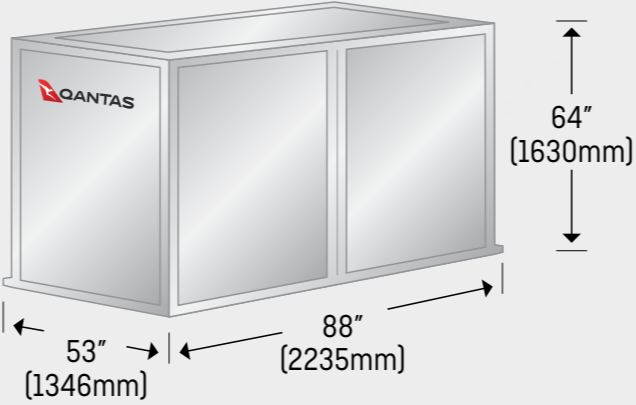

PEB

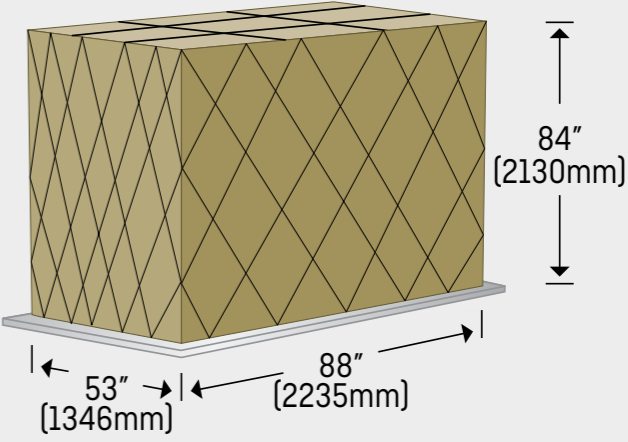

B787-8 Unit Load Devices

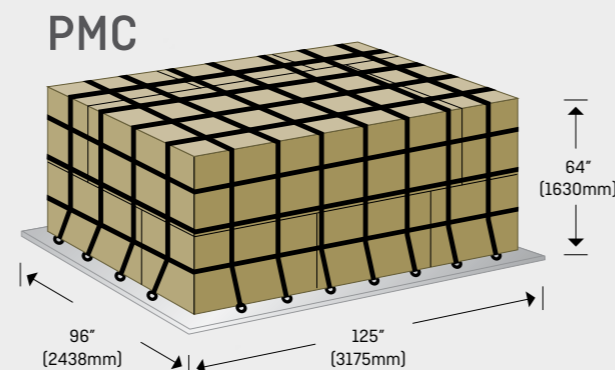
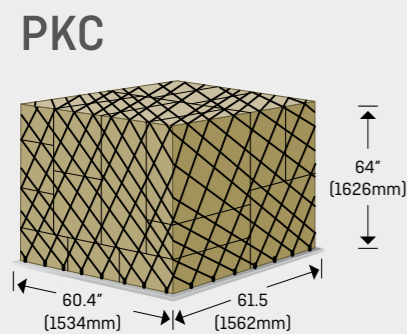
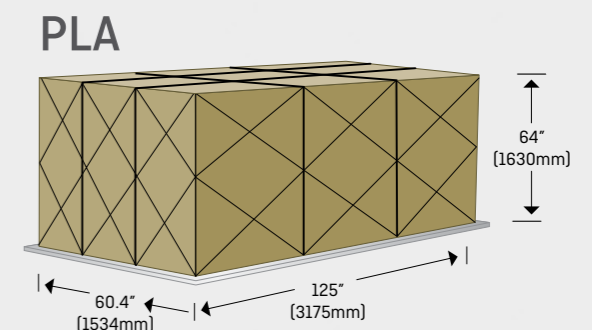
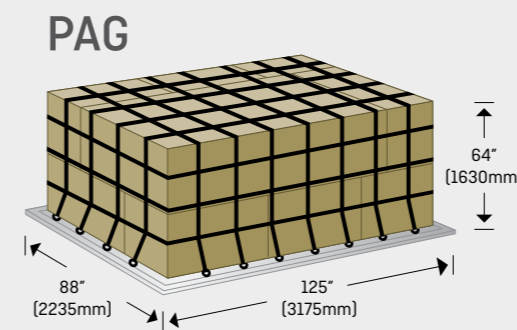
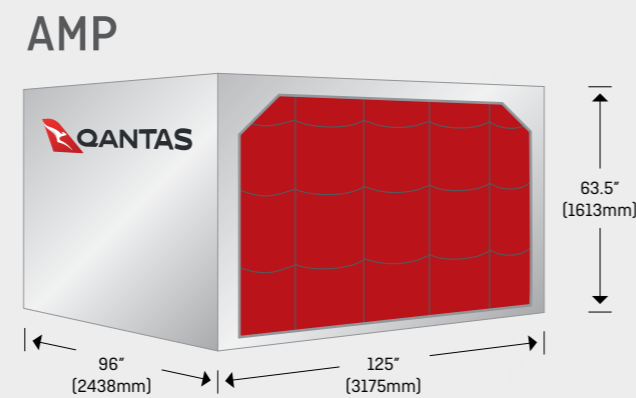
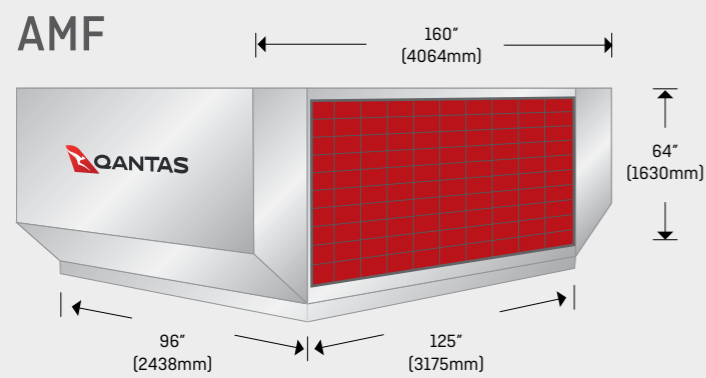
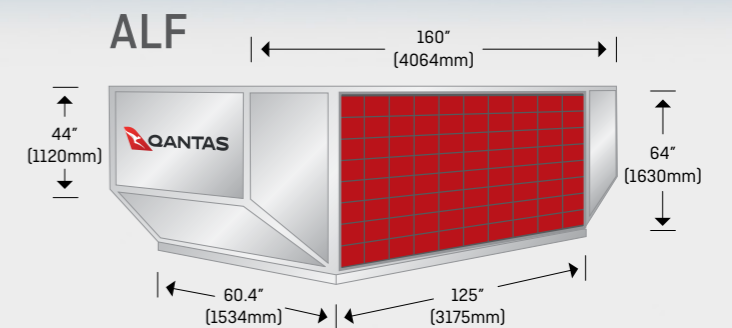
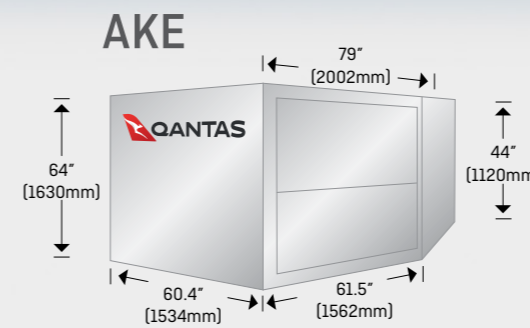
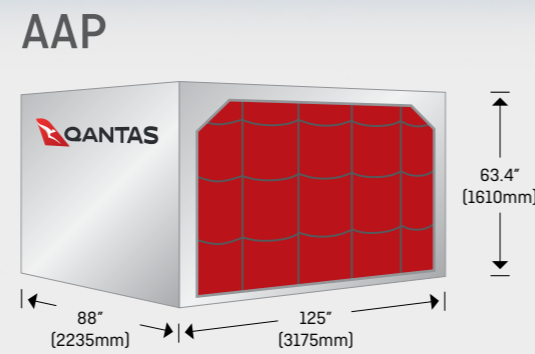
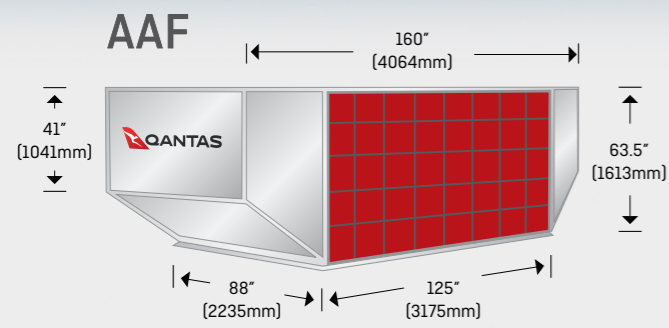
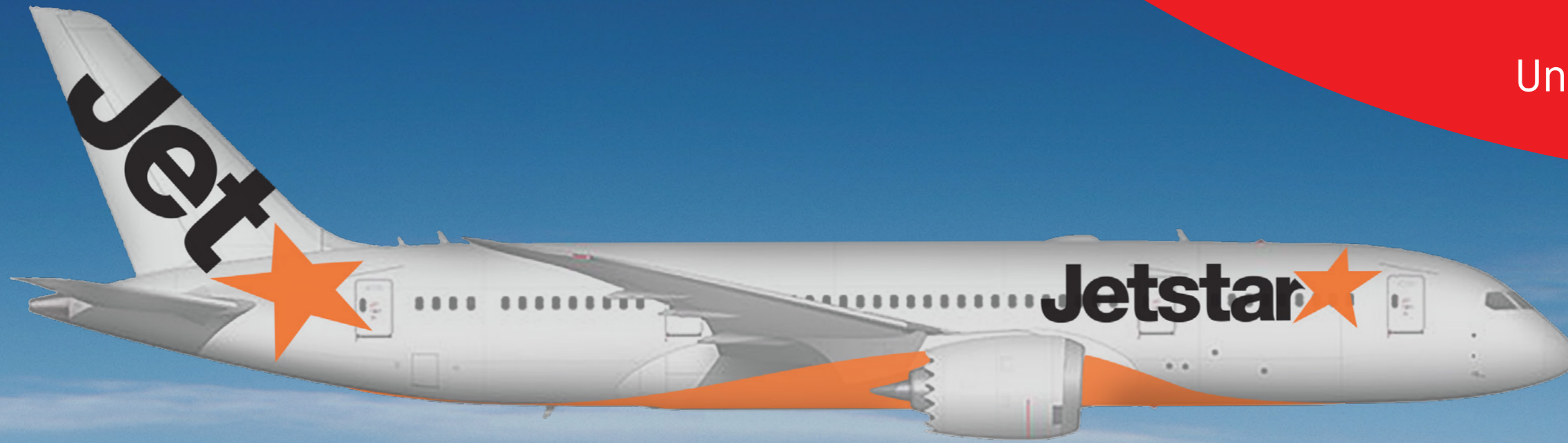

A321

Unit Load Devices

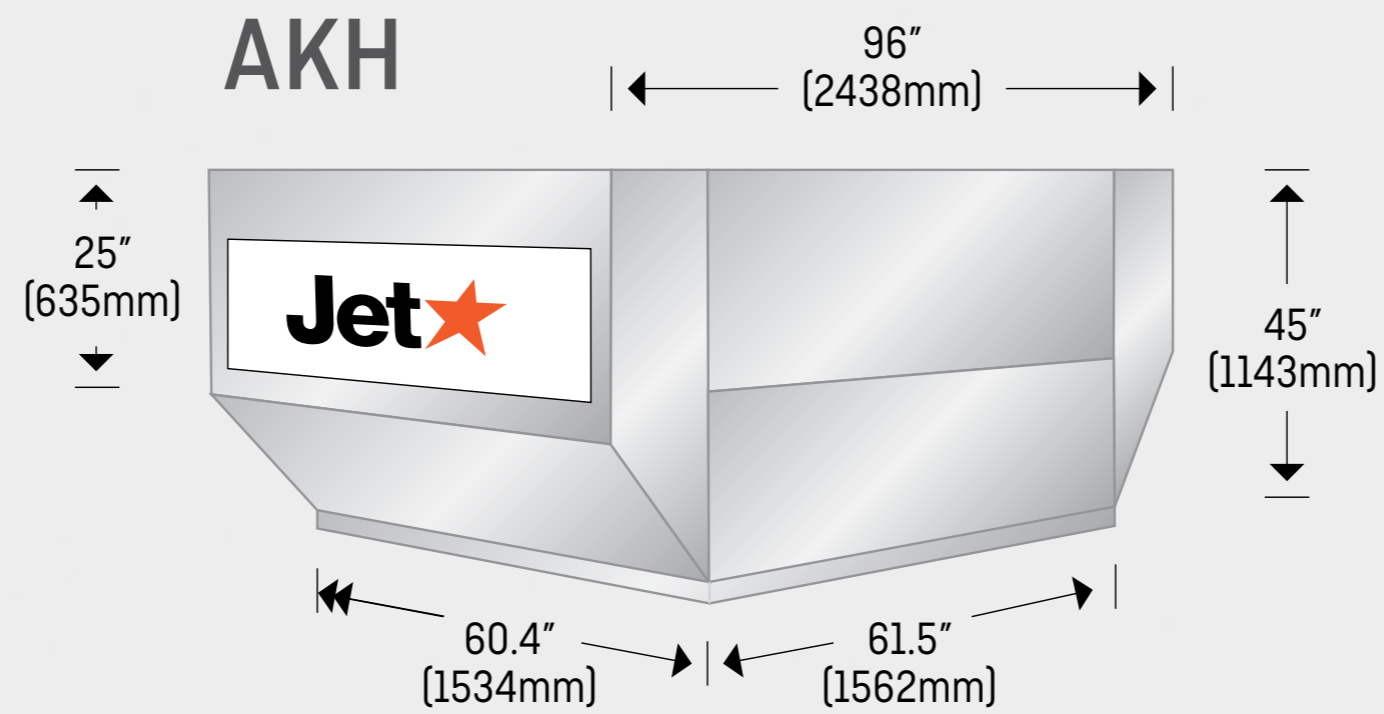

A320

Unit Load Devices

